

User Manual

Contents

Chapter 1. Overview.....	3
Drone.....	3
Remote Controller.....	4
Remote Controller without a Screen.....	4
Remote Controller with a Screen.....	4
Chapter 2. Getting Started.....	6
Preparing the Drone and Remote Controller.....	6
Remote Controller Preparation.....	6
Remote Controller Without a Screen.....	6
Remote Controller With a Screen.....	6
Activating the Drone.....	6
Firmware Update.....	7
Chapter 3. Flight Safety.....	8
Flight Safety and Precautions.....	8
Requirements of Flight Environment.....	8
Pre-Flight Checklist.....	8
Chapter 4. Flight Operation.....	10
Auto Takeoff/Landing.....	10
Starting and Stopping the Motors.....	10
Control Stick Mode.....	11
Chapter 5. Intelligent Flight Modes.....	13
Intelligent Flight Modes.....	13
Chapter 6. Drone.....	14
Flight Mode.....	14
Drone Status Indicators.....	15
Return to Home	16
RTH Notice.....	16
Sensing System.....	17
Sensing System Notice.....	17
Vision Assist.....	18
Propellers.....	19
Smart Battery.....	20
Smart Battery Notice.....	20
Using the Battery.....	21
Charging the Battery.....	22
Gimbal and Camera.....	24
Gimbal Angle.....	24
Gimbal Operation Modes.....	24
Gimbal and Camera Notice.....	24
Storing and Exporting Media Files.....	25
Storing and Exporting Media Files.....	25
Material Transfer	26
Chapter 7. Remote Controller.....	27
Remote Controller Without a Screen.....	27
Powering On/Off.....	27
Charging the Remote Controller.....	27
Controlling the Gimbal and Camera.....	27
Flight Mode Switch.....	28
Flight Pause/RTH Button.....	28
Customizable Button.....	28
Battery Level LEDs.....	28
Remote Controller Alert.....	29
Optimal Transmission Zone.....	29
Linking the Remote Controller.....	29
Remote Controller With a Screen.....	30
Powering On/Off.....	30
Charging the Remote Controller.....	30
Controlling the Gimbal and Camera.....	30
Flight Mode Switch.....	31
Flight Pause/RTH Button.....	31
Customizable Buttons.....	31
Remote Controller LEDs.....	31
Remote Controller Alert.....	32
Optimal Transmission Zone.....	33
Linking the Remote Controller.....	33
Operating the Touchscreen.....	33

Chapter 1. Overview

Drone

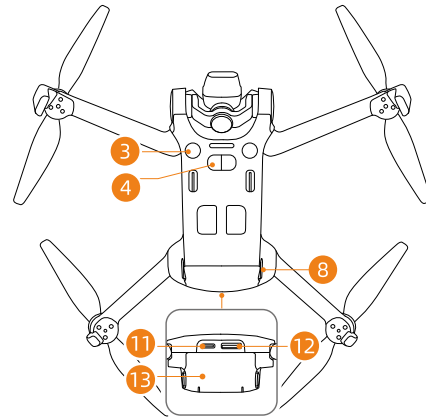
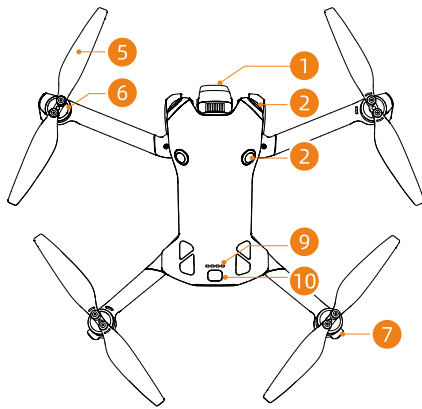

1. Gimbal and Camera
2. Omnidirectional Vision System *
3. Downward Vision System
4. Infrared Sensing System
5. Propellers
6. Motors
7. Drone Status Indicators
8. Battery Buckles
9. Battery Level LEDs
10. Power Button
11. USB-C Port
12. microSD Card Slot
13. Smart Battery

*The omnidirectional vision system can sense obstacles in horizontal directions and above.

Remote Controller

Remote Controller without a Screen

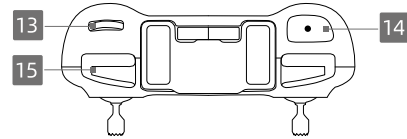
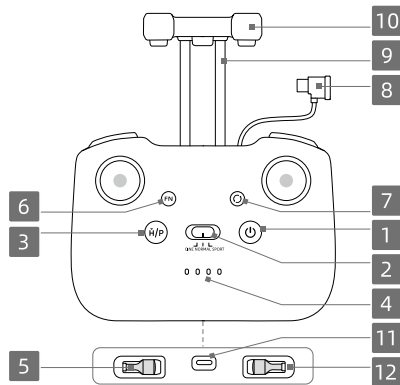

1. Power Button
2. Flight Mode Switch
3. Flight Pause/Return to Home (RTH) Button
4. Battery Level LEDs
5. Control Sticks
6. Customizable Button
7. Photo/Video Button
8. Remote Controller Cable
9. Mobile Device Holder
10. Antennas
11. USB-C Port
12. Control Stick Storage Slots
13. Gimbal Dial
14. Shutter/Record Button
15. Mobile Device Slot

Remote Controller with a Screen

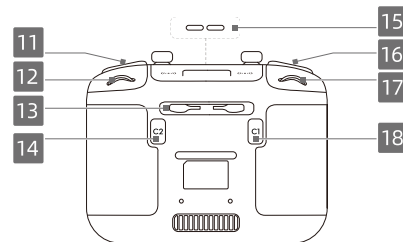
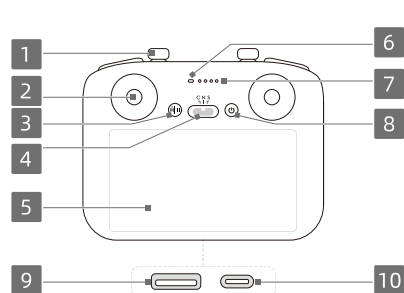

1. Antennas
2. Control Sticks
3. Flight Pause/Return to Home (RTH) Button
4. Flight Mode Switch
5. Touchscreen
6. Status LED
7. Battery Level LEDs
8. Power Button
9. microSD Card Slot
10. USB-C Port
11. Focus/Shutter Button
12. Camera Control Dial
13. Control Stick Storage Slots
14. Customizable C2 Button
15. Speaker
16. Record Button
17. Gimbal Dial
18. Customizable C1 Button

Chapter 2. Getting Started

Preparing the Drone and Remote Controller

1. The battery is shipped in hibernation mode for safety. Charge to activate the battery for the first time. Connect a USB charger to the USB-C port on the drone to charge.
2. Remove the gimbal protector from the camera. Unfold the front arms and the rear arms.
3. Remove the control sticks from the storage slots and mount them on the remote controller.
4. Pull out the mobile device holder. Choose the appropriate remote controller cable based on the port type of your mobile device (the cable with a USB-C connector is connected by default). Place your mobile device in the holder, then connect the end of the cable without the remote controller logo to your mobile device. Make sure your mobile device is securely in place.



Warning:

- If a USB connection prompt appears when an Android mobile device is used, select the option to charge only. Other options may cause the connection to fail.
- Adjust the mobile device holder to make sure your mobile device is firmly secure.

Remote Controller Preparation

Remote Controller Without a Screen

1. Take out the control sticks from their storage slots and attach them to the remote controller.
2. Extend the smartphone holder. A USB-C remote controller cable is connected by default. Select the correct remote controller cable for your smartphone's port type. Take the end of the cable that lacks the remote controller logo from the slot and put the cable behind the remote controller. Secure your smartphone in the holder, then connect the cable to your smartphone.



Warning:

- If a USB connection prompt appears when an Android smartphone is used, select the option to charge only. Other options may cause the connection to fail.

Remote Controller With a Screen

1. Take out the control sticks from the storage compartments and attach them to the remote controller.
2. Unfold the antennas.
3. The remote controller must be activated prior to initial use and requires an internet connection for activation. Press, then press and hold the power button to turn on the remote controller. Follow the on-screen instructions to activate the remote controller.

Activating the Drone

The drone must be activated before its initial use. To turn on the drone and remote controller, press the power button once, then press and hold it. Follow the on-screen instructions in the flight control app to complete the activation process. An internet connection is necessary for activation.

Firmware Update

A prompt will appear in the flight control app when a firmware update is available. Update the firmware whenever prompted to ensure the optimal user experience.

 **Tip:**

During the update process, it is normal for the gimbal to go limp, the drone status indicators to blink, and the drone to reboot. Wait patiently for the update to complete.

Chapter 3. Flight Safety

Flight Safety and Precautions

After completing pre-flight preparations, it is advised to practice your flying skills safely. Choose an appropriate area to fly, following the specified flight requirements and restrictions. Always adhere to local laws and regulations while flying. Review the relevant documents before flight to ensure the product is used safely.

Requirements of Flight Environment

1. Operate the drone, remote controller, battery, battery charger, and battery charging hub in a dry environment.
2. DO NOT use the drone, remote controller, battery, battery charger, and the battery charging hub near accidents, fire, explosions, floods, tsunamis, avalanches, landslides, earthquakes, dust, sandstorms, salt spray, or fungus.
3. DO NOT operate the drone near bird flocks.
4. When the GNSS signal is weak, fly the drone in environments with good lighting and visibility. The vision system may not work properly in poor light conditions. Only fly the drone in the daytime.
5. Minimize interference by avoiding areas with high levels of electromagnetism, such as locations near power lines, base stations, electrical substations, and broadcasting towers.
6. The performance of the drone and its battery is limited at high altitudes. Fly with caution and do not exceed the specified altitude.
7. The braking distance of the drone increases with altitude. At higher altitudes, ensure you reserve adequate braking distance to maintain flight safety.
8. GNSS cannot be used on the drone in polar regions. Use the vision system instead.
9. DO NOT take off from moving objects such as cars, ships, and airplanes.
10. DO NOT take off from solid-colored surfaces or surfaces with strong reflections such as a car roof.
11. Be careful when taking off in the desert or from a beach to avoid sand entering the drone.
12. DO NOT operate the drone in an environment at risk of a fire or explosion.
13. DO NOT fly in severe weather conditions such as strong winds, snow, rain, and fog.
14. Fly only in open areas. Tall buildings and large metal structures can affect the accuracy of the onboard compass and GNSS system. After takeoff, ensure you receive a voice prompt confirming the Home Point update before continuing. If the drone takes off near buildings, the Home Point accuracy may be compromised. In such cases, closely monitor the drone's position during auto RTH and manually control the landing when near the Home Point.
15. Keep the drone within visual line of sight (VLOS). Avoid mountains and trees that can block GNSS signals. Flights beyond visual line of sight (BVLOS) should only be conducted if the drone performance, pilot knowledge and skills, and operational safety management comply with local BVLOS regulations. Steer clear of obstacles, crowds, trees, and bodies of water. For safety reasons, do not fly near airports, highways, railway stations, railway lines, city centers, or other sensitive areas without obtaining the necessary permits or approvals as required by local regulations.

Pre-Flight Checklist

1. Remove any protective parts from the drone.
2. Make sure the Smart Battery and the propellers are mounted securely.
3. Make sure the remote controller, mobile device, and Smart Battery are fully charged.
4. Make sure the drone arms are unfolded.

5. Make sure the gimbal and camera are functioning normally.
6. Make sure that there is nothing obstructing the motors and that they are functioning normally.
7. Make sure that the flight control app is successfully connected to the drone.
8. Make sure all camera lenses and sensors are clean.
9. Make sure the **Obstacle Avoidance Action** is set in the flight control app, and the **Max Altitude**, **Max Distance** and **Auto RTH Altitude** are all set properly according to local laws and regulations.

Chapter 4. Flight Operation

Auto Takeoff/Landing

Auto Takeoff

Launch the flight control app and enter the camera view. Tap . If conditions are safe for takeoff, press and hold the button to confirm.

Auto Landing

If conditions are safe to land, tap , then tap and hold to confirm. Auto landing can be canceled by tapping . Motors will stop automatically after landing.

Tip:

- The drone supports energy-saving mode. When the temperature of the drone rises to a certain temperature, the drone will enter the energy-saving mode. If the temperature of the drone continues to rise, it will power off to prevent overheating.
- Choose an appropriate place for landing.

Starting and Stopping the Motors

Starting the Motors

Perform one of the Combination Stick Commands (CSC) as shown below to start the motors. Once the motors have started spinning, release both sticks simultaneously.

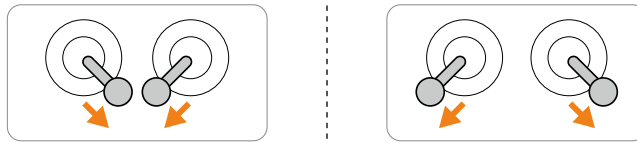

Stopping the Motors

The motors can be stopped in two ways:

Method 1: When the drone has landed, push the throttle stick down and hold until the motors stop.

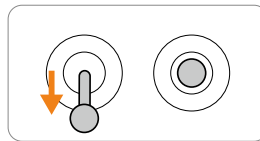

Method 2: When the drone has landed, perform one of the CSC as shown below until the motors stop.



Warning:

! Stopping the motors mid-flight will cause the drone to crash.

The default setting for **Emergency Propeller Stop** in the the flight control app is **Emergency Only**, which means that the motors can only be stopped mid-flight when the drone detects that it is in an emergency situation such as the drone is involved in a collision, a motor has stalled, the drone is rolling in the air, or the drone is out of control and is ascending or descending very quickly. To stop the motors mid-flight, perform the same CSC that was used to start the motors. Note that you need to hold the control sticks for two seconds while performing the CSC to stop the motors. **Emergency Propeller Stop** can be changed to **Anytime** in the flight control app. Use this option with caution.

Control Stick Mode

The control sticks of the remote controller can be used to control the drone movements. The control sticks can be operated in Mode 1, Mode 2, or Mode 3, as shown below.

The default control mode of the remote controller is Mode 2. In this manual, Mode 2 is used as an example to illustrate how to use the control sticks. The more the stick is pushed away from the center, the faster the drone moves.

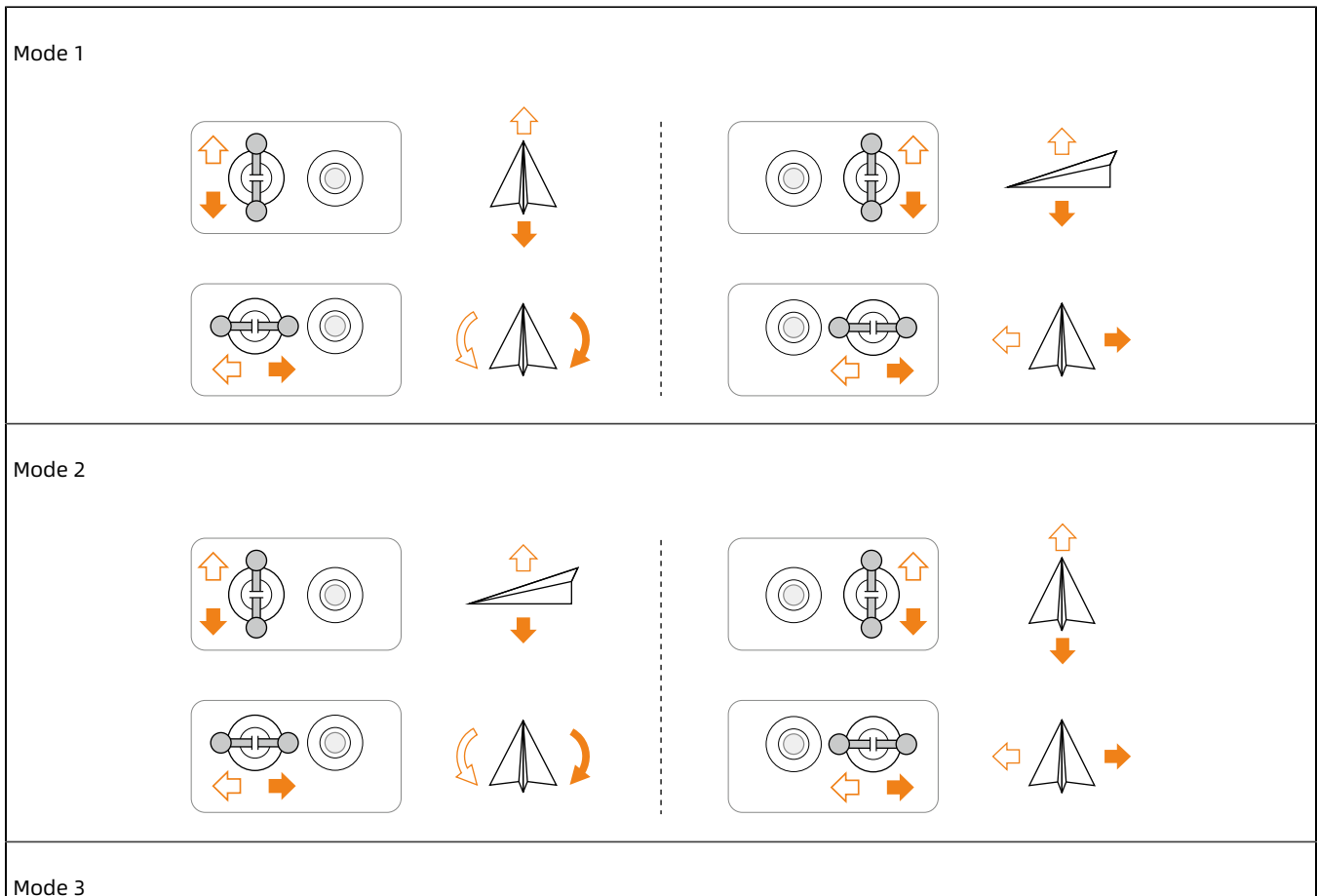

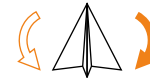
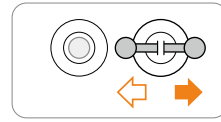
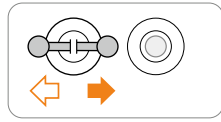
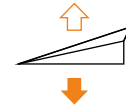
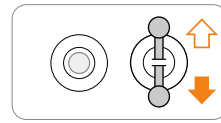
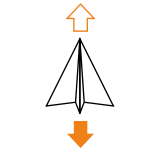
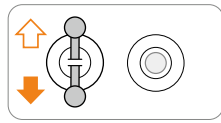

Chapter 5. Intelligent Flight Modes

Intelligent Flight Modes

The drone supports multiple intelligent flight functions, significantly enhancing the convenience and quality of photography. The features include:

- **FocusTrack:** Automatically identifies and tracks targets.
- **QuickShots:** Provides various preset flight paths to create professional short videos.
- **Hyperlapse:** Achieves dynamic time-lapse shooting during flight.
- **Waypoint Flight:** Waypoint Flight enables the drone to capture images during a flight according to the waypoint flight route generated by the preset waypoints.
- **Cruise Control:** This enables the drone to lock the current control stick input of the remote controller when conditions permit, and to automatically fly at the speed corresponding to the current control stick input. Without the need to continually move the control sticks, longdistance flights become more effortless, and image shaking which often happens during manual operating can be avoided.

Chapter 6. Drone

Flight Mode

The drone supports the following flight modes, which can be switched via the Flight Mode switch on the remote controller.

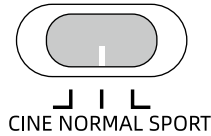

Position	Flight Mode
SPORT	Sport Mode: The maximum horizontal flight speed of the drone will be higher when compared with Normal mode. Note that obstacle sensing is disabled in Sport mode.
NORMAL	Normal Mode: Normal mode is suitable for most flight scenarios. The drone can hover precisely, fly stably, and use Intelligent Flight Modes.
CINE	Cine Mode: Cine mode is based on Normal mode with a limited flight speed, making the drone more stable during recording.

The drone automatically changes to Attitude (ATTI) mode when the vision system is unavailable or disabled and the GNSS signal is weak or the compass experiences interference. In ATTI mode, the drone may be more easily affected by its surroundings. Environmental factors such as wind can result in horizontal drift of the drone, which may present hazards, especially when flying in confined spaces. The drone will not be able to hover or brake automatically, therefore the pilot should land the drone as soon as possible to avoid accidents. When the vision system is unavailable or disabled and the GNSS signal is weak or the compass experiences interference, the drone automatically switches to Attitude (ATTI) mode. In ATTI mode, the drone is more susceptible to environmental influences, such as wind, which can cause horizontal drift. This drift can pose hazards, particularly in confined spaces. In ATTI mode, the drone cannot hover or brake automatically, so the pilot should promptly land the drone to prevent accidents.



Tip:

- The flight modes are only effective for manual flight and cruise control.



Warning:





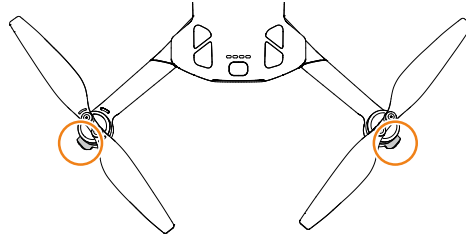





- In Sport mode, the drone's responsiveness is greatly enhanced, resulting in significant movement from minimal control stick input on the remote controller. It is essential to maintain sufficient maneuvering space during flight.
- The vision system is disabled in Sport mode, which means the drone cannot sense obstacles on its route automatically. You must stay alert to the surrounding environment and control the drone to avoid obstacles.
- The maximum speed and braking distance of the drone significantly increase in Sport mode. A minimum braking distance of 30 m is required in windless conditions.
- A minimum braking distance of 10 m is required in windless conditions while the drone is ascending and descending in Sport mode or Normal mode.

Drone Status Indicators



When the drone is powered on, but the motors are not running, the drone status indicators will display the current status of the drone. After the motors start, the drone status indicators will blink green.

Drone Status Indicators

Normal States		
	Blinks red, yellow, and green alternately	Powering on and performing self-diagnostic tests
	Blinks yellow four times	Warming up
	Blinks green slowly	GNSS enabled
	Blinks green twice repeatedly	Vision systems enabled
	Blinks yellow slowly	GNSS and vision system disabled (ATTI mode enabled)
Warning States		
	Blinks yellow quickly	Remote controller signal lost
	Blinks red slowly	Takeoff is disabled (e.g., low battery) *
	Blinks red quickly	Critically low battery
	Solid red	Critical error
	Blinks red and yellow alternately	Compass calibration required

* If the drone cannot take off while the status indicators are blinking red slowly, view the warning prompt in the flight control app.



Return to Home

Carefully read the contents of this section to ensure you are familiar with the behavior of the drone in Return-to-Home (RTH).

The Return to Home (RTH) function will automatically fly the drone back to the last recorded Home Point. RTH can be triggered in three ways: the user actively triggers RTH, the drone has low battery, or the remote controller signal has been lost (Failsafe RTH is triggered). If the drone has recorded the Home Point successfully and the positioning system is functioning normally, when the RTH function is triggered, the drone will automatically fly back and land at the Home Point.



Note:

- **Home Point:** The Home Point will be recorded at takeoff as long as the drone has a strong GNSS signal  26 or the lighting is sufficient. After the Home Point is recorded, the flight control app will issue a voice prompt. If it is necessary to update the Home Point during a flight (such as if you have changed your position), the Home Point can be manually updated in  > **Safety** page in the flight control app.

RTH Notice



Warning:

- During Advanced RTH, when the remote controller signal is normal, the pitch stick can be used to control the flight speed. However, the orientation and altitude cannot be adjusted, and the aircraft cannot be directed to fly left or right. Continuously pushing the pitch stick to accelerate will increase battery power consumption. If the flight speed exceeds the effective sensing speed, the aircraft will be unable to bypass obstacles. In such cases, the aircraft will brake, hover in place, and exit RTH if the pitch stick is pushed all the way down. Once the pitch stick is released, the aircraft can be controlled again.
- The aircraft will exit RTH if the surrounding environment is too complex to complete RTH, even if the sensing system is working properly.
- RTH cannot be triggered during auto landing.
- It is important to set a suitable RTH altitude before each flight. Launch the flight control app and set the RTH altitude.
- The aircraft cannot sense obstacles during RTH if the environment conditions are not suitable for the sensing system.
- The aircraft may not be able to return to a Home Point if the wind speed is too high. Fly with caution.
- Pay extra attention to small or fine objects (such as tree branches or power lines) or transparent objects (such as water or glass) during RTH. Exit RTH and control the aircraft manually in an emergency.
- The RTH Altitude cannot be changed during RTH.

Sensing System

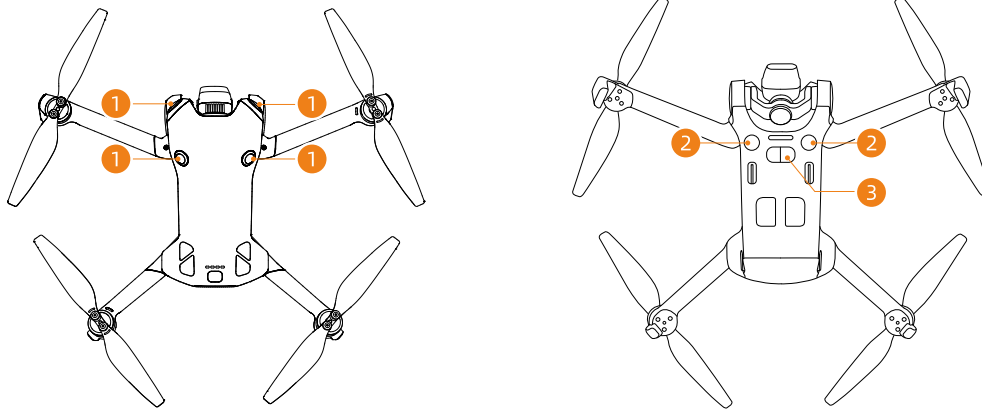

1. Omnidirectional Vision System
2. Downward Vision System
3. Infrared Sensing System

The omnidirectional vision system works best with adequate lighting and clearly marked or textured obstacles. The omnidirectional vision system will activate automatically when the drone is in Normal or Cine mode and **Obstacle Avoidance Action** is set to **Bypass** or **Brake** in the fly control app. The positioning function is applicable when GNSS signals are unavailable or weak.

The Advanced Pilot Assistance Systems feature is available in Normal mode and Cine mode. When enabled, the drone will respond to your commands while simultaneously planning its path based on control stick inputs and the flight environment. This feature helps to avoid obstacles, achieve smoother footage, and enhance the overall flying experience. If needed, the drone can be stopped by pressing the Flight Pause button on the remote controller. Upon pressing the button, the drone will brake and hover for three seconds, awaiting further pilot commands.

To enable this feature, open the flight control app, go to  > **Safety** > **Obstacle Avoidance Action**, and select **Bypass**.

Tip:

- When Vision Positioning and Obstacle Sensing are disabled, the drone relies only on GNSS to hover, omnidirectional obstacle sensing is unavailable, and the drone will not automatically decelerate during descent close to the ground. Extra caution is required when Vision Positioning and Obstacle Sensing are disabled.
- Disabling Vision Positioning and Obstacle Sensing takes effect only when flying manually, and will not take effect when using RTH, auto landing, or using Intelligent Flight Modes.

Sensing System Notice

Warning:

- The vision system cannot work properly near surfaces without clear pattern variations or where the lighting is too weak or too strong. The vision system cannot work properly in the following situations:
 - Flying near monochrome surfaces.
 - Flying near highly reflective surfaces.
 - Flying near water or transparent surfaces.



- Flying near moving surfaces or objects.
- Flying in an area with frequent and drastic lighting changes.
- Flying near extremely dark or bright surfaces.
- Flying near surfaces that strongly reflect or absorb infrared waves (e.g., mirrors).
- Flying near surfaces without clear patterns or textures.
- Flying near surfaces with repeating identical patterns or textures (e.g., tiles with the same design).
- Flying near obstacles with small surface areas (e.g., tree branches, and power lines).
- Keep the sensors clean at all times. DO NOT scratch or tamper with the sensors. DO NOT use the drone in dusty or humid environments.
- DO NOT fly when it is rainy, smoggy, or the visibility is lower than 100 m.
- DO NOT obstruct the sensing system.
- Check the following each time before takeoff:
 - Make sure there are no stickers or any other obstructions over the glass of the sensing system.
 - Use a soft cloth if there is any dirt, dust, or water on the glass of the sensing system. DO NOT use any cleaning product that contains alcohol.
- Pay attention to the flight environment. The sensing system only works in certain scenarios and cannot replace human control and judgment. During a flight, always pay attention to the surrounding environment and the warnings in the flight control app, and be responsible for and maintain control of the drone at all times.
- If there is no GNSS available, the downward vision system will assist with drone positioning, and works best at a limited altitude. Extra caution is required if the altitude of the drone is above 30 m as the vision positioning performance may be affected.
- In low-light environments, the vision system may not achieve optimal positioning performance even if the auxiliary light is turned on. Fly with caution if the GNSS signal is weak in such environments.
- The downward vision system may not work properly when the drone is flying near water. Therefore, the drone may not be able to actively avoid water below it when landing. It is recommended to maintain flight control at all times, make reasonable judgments based on the surrounding environment, and avoid over-relying on the downward vision system.
- The vision system cannot accurately identify large structures with frames and cables, such as tower cranes, high-voltage transmission towers, high-voltage transmission lines, cable-stayed bridges, and suspension bridges.

Vision Assist

The vision assist view, powered by the vision systems, changes the image on the view from the corresponding vision sensors according to the flight speed direction to help users navigate and observe obstacles during flight. Swipe left on the attitude indicator, right on the mini map, or tap the icon in the lower right corner of the attitude indicator to switch to the vision assist view.



Warning:



- When using vision assist, the quality of the video transmission may be lower due to transmission bandwidth limits, cell phone performance, or the video transmission resolution of the screen on the remote controller.
- Vision assist should be used for reference only. Glass walls and small objects such as tree branches, electric wires, and kite strings cannot be displayed accurately.
- Vision assist is not available when the drone has not taken off or when the video transmission signal is weak.
- When the direction is not locked in a specific direction, the vision assist view automatically switches to the current flight direction. Tap any other directional arrow to switch the direction of the vision assist view for a while before returning to the view of the current flight direction.
- When the vision assist direction is locked in a specific direction, tap any other arrow to switch the vision assist view for a while before returning to the currently locked direction.

Collision Warning

When an obstacle in the current view direction is detected, the vision assist view shows a collision warning. The color of the warning is determined by the distance between the obstacle and the drone. Yellow and red colors indicate the relative distance ranging from far to near.



Tip:

- The FOV of the vision assist in all directions is limited. It is normal not to see obstacles in the field of view during a collision warning.
- The collision warning is not controlled by the **Display Radar Map** switch and remains visible even when the radar map is switched off.
- A collision warning appears only when the vision assist view is displayed in the small window.

Propellers

Attach the marked propellers to the motors of the marked arm, and the unmarked propellers to the motors of the unmarked arm. Use the screwdriver from the drone package to mount and remove the propellers. Make sure the screws are properly tightened when mounting the propellers.

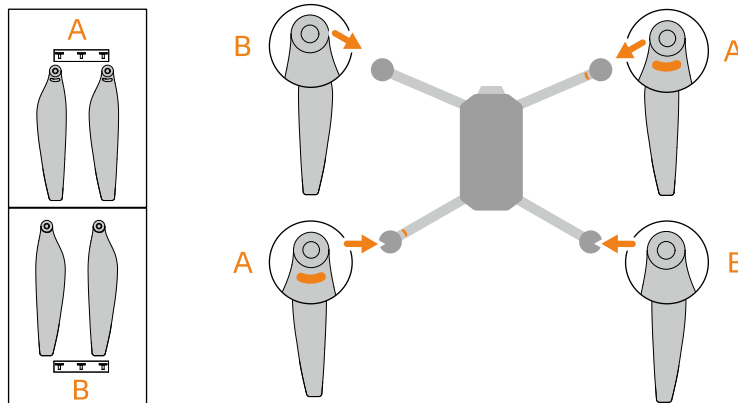

Warning:



- Propellers are consumable components. Purchase additional propellers if necessary.
- Make sure that all propellers are in good condition before each flight.
- To avoid injury, stay away from rotating propellers or motors.
- Make sure the motors are mounted securely and rotating smoothly. Land the drone immediately if a motor is stuck and unable to rotate freely.
- DO NOT attempt to modify the structure of the motors.
- Make sure to only use the screwdriver from the drone package for mounting propellers. Using other screwdrivers may damage the screws.
- Make sure to keep the screws vertical while tightening them. The screws should not be at a tilted angle to the mounting surface. After installation is complete, check whether the screws are flush and rotate the propellers to check for any abnormal resistance.
- The propeller blades are sharp. Handle with care to avoid personal injury or propeller deformation.
- Make sure that the propellers and motors are installed securely before each flight.
- The screwdriver is only for mounting the propellers. DO NOT use the screwdriver to disassemble the drone.
- If a propeller is broken, remove the two propellers and screws on the corresponding motor and discard them. Use two propellers from the same package. DO NOT mix with propellers from other packages.

Smart Battery

Smart Battery Notice



Warning:

- Read and strictly follow the instructions in this manual before using the battery. You shall take full responsibility for all operations and usage.

1. The battery cannot be charged if the drone is powered on.
2. Make sure the battery is mounted securely with a clicking sound. DO NOT launch the drone when the battery is not securely mounted, as this may cause poor contact between the battery and the drone and present hazards.
3. To prevent damage, the battery only charges when the battery temperature is between 5° and 40° C (41° and 104° F). The ideal charging temperature is from 22° to 28° C (71.6° to 82.4° F). Charging at the ideal temperature range can prolong battery life. Charging stops automatically if the temperature of the battery cells is too high during charging.
4. Low-Temperature Notice:
 - Batteries cannot be used in extremely low-temperature environments of lower than -10° C (14° F).
 - Battery capacity is significantly reduced when flying at low temperatures. Make sure to fully charge the battery before takeoff. Hover the drone in place for a while to warm up the battery after takeoff.
 - It is recommended to warm up the battery to at least 10° C (50° F) before takeoff when flying in low-temperature environments. The ideal temperature to warm up the battery is above 20° C (68° F).

- The reduced battery capacity in low-temperature environments reduces the wind speed resistance performance of the drone. Fly with caution.
- Take extra caution when flying at a high elevation with a low temperature.

5. A fully charged battery will automatically discharge when it is idle for a period of time. Note that it is normal for the battery to emit heat during the discharging process.

Using the Battery

Checking the Battery Level

Press the power button once to check the current battery level.

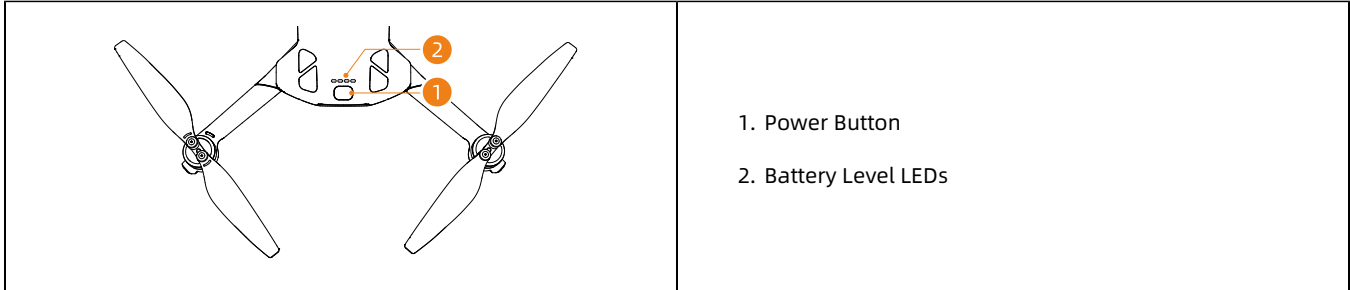

1. Power Button
2. Battery Level LEDs

The battery level LEDs display the power level of the battery during charging and discharging. The statuses of the LEDs are defined below:

● LED is on

⦿ LED is flashing

○ LED is off

Blinking Pattern	Battery Level
● ● ● ●	88-100%
● ● ● ⦿	76-87%
● ● ● ○	63-75%
● ● ⦿ ○	51-62%
● ● ○ ○	38-50%
● ⦿ ○ ○	26-37%
● ○ ○ ○	13-25%

Blinking Pattern	Battery Level
	0-12%

Powering On/Off

Press, then press and hold the power button to power the drone on or off. The battery level LEDs display the battery level when the drone is powered on. The battery level LEDs turn off when the drone is powered off.

Charging the Battery

Fully charge the battery before each use. It is recommended to use the chargers that support the USB PD fast charging protocol. The battery cannot be charged if the drone is powered on.

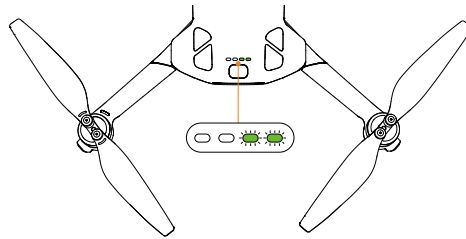

If the LEDs as shown below blink simultaneously, this indicates the battery is malfunctioning. Remove the battery from the drone, insert the battery again and make sure that it is securely mounted.

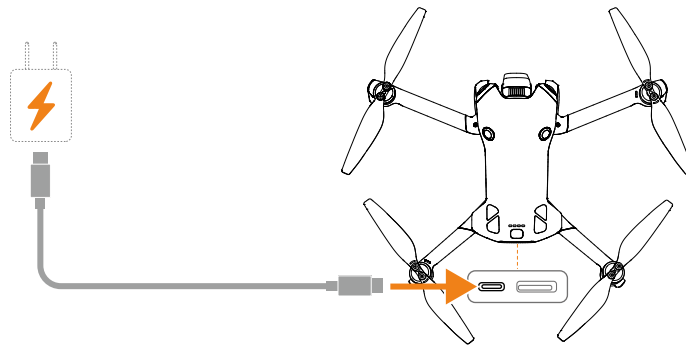

Using a Charger



The table below shows the battery level during charging.

Blinking Pattern	Battery Level
	0-50%
	51-75%
	76-99%

Blinking Pattern	Battery Level
	100%

i Tip:

- The blinking frequency of the battery level LEDs differs depending on the USB charger used. If the charging speed is fast, the battery level LEDs will blink quickly.
- Four LEDs blinking simultaneously indicates the battery is damaged.

Using the Charging Hub

Insert the batteries into the charging hub. Connect the charging hub to a power outlet using a charger. The battery with the highest power level will be charged first. The rest will be charged in sequence according to their power levels. The battery can be stored in the charging hub after charging.

! Warning:

- The environmental temperature affects the charging speed. Charging is faster under normal temperature and a well ventilated environment.
- Place the charging hub on a flat and stable surface when in use. Make sure the device is properly insulated to prevent fire hazards.
- DO NOT touch the metal terminals on the battery ports.
- Clean the metal terminals with a clean, dry cloth if there is any noticeable build.







Status LED Descriptions

Each battery port of the charging hub has its corresponding status LED array. Check battery levels by pressing the function button once. The battery level LED statuses are the same as those on the aircraft. For details, refer to aircraft battery level LEDs statuses and descriptions.

Blinking Pattern	Descriptions
Status LEDs in an array blink quickly successively	The battery in the corresponding battery port is being charged using a USB PD charger.
Status LEDs in an array blink slowly successively	The battery in the corresponding battery port is being charged using a normal charger.
Status LEDs in an array are solid	The battery in the corresponding battery port is fully charged.
All status LEDs blink in sequence	No battery is inserted.

Battery Protection Mechanisms

The battery level LEDs can display battery protection notifications triggered by abnormal charging conditions.

LEDs	Blinking Pattern	Status
	LED2 blinks twice per second	Overcurrent detected
	LED2 blinks three times per second	Short circuit detected
	LED3 blinks twice per second	Overcharge detected
	LED3 blinks three times per second	Over-voltage charger detected
	LED4 blinks twice per second	Charging temperature is too low
	LED4 blinks three times per second	Charging temperature is too high

Gimbal and Camera

Gimbal Angle

Use the gimbal dial on the remote controller to control the tilt of the gimbal. Alternatively, do so through the camera view in the flight control app. Press and hold the screen until the gimbal adjustment bar appears. Drag the bar to control the gimbal's angle.

Gimbal Operation Modes

Two gimbal operation modes are available. Switch between the different operation modes in  > **Control**.

Follow Mode: The angle of the gimbal remains stable relative to the horizontal plane. This mode is suitable for capturing stable images.

FPV Mode: When the drone is flying forward, the gimbal rolls in sync with the rolling drone to provide a first-person flying experience.

Gimbal and Camera Notice



Warning:

- Make sure there are no stickers or objects on the gimbal before taking off. DO NOT tap or knock the gimbal after the drone is powered on. Launch the drone from open and flat ground to protect the gimbal.
- Remove the gimbal protector before powering on the drone. Attach the gimbal protector when the drone is not in use.
- Precision elements in the gimbal may be damaged by a collision or impact, which may cause the gimbal to function abnormally.
- Avoid getting dust or sand on the gimbal, especially in the gimbal motors.



- A gimbal motor may enter protection mode if the gimbal is obstructed by other objects when the drone is put on uneven ground or on grass, or if the gimbal experiences an excessive external force, such as during a collision. Wait for the gimbal to return to normal or restart the device.
- DO NOT apply external force to the gimbal after the drone is powered on.
- DO NOT add any extra payload other than an official accessory to the gimbal, as this may cause the gimbal to function abnormally or even lead to permanent motor damage.
- Flying in heavy fog or clouds may make the gimbal wet, leading to temporary failure. The gimbal will recover full functionality once it is dry.
- If there are strong winds, the gimbal may vibrate while recording.
- If the gimbal tilt angle is large during flight, and the drone tilts forward due to acceleration or deceleration, the gimbal will enter limit protection mode and automatically adjust the angle downward.
- After powering on, if the drone is not placed flat for an extended period or if it is significantly shaken, the gimbal may stop working and enter protection mode. In this case, place the drone flat and wait for it to recover.

**Warning:**

- Avoid exposing the camera lens to environments with laser beams, like laser shows, or directing the camera at intense light sources for long durations, such as the sun on a clear day, to prevent sensor damage.
- Clean the lens with a lens cleanser to maintain image quality and avoid damage.
- Ensure that no ventilation holes on the camera are obstructed.

Storing and Exporting Media Files

Storing and Exporting Media Files

The drone supports the use of a microSD card to store your photos and videos. It is recommended to use U3 or V30 and above microSD cards.

Export your photos and videos as the following methods.

- Use Material Transfer feature to export the footage to a mobile device.
- Connect the drone to a computer using a data cable, export the footage in the microSD card mounted on the drone.
- Remove the microSD card from the drone and insert it into a card reader, and export the footage in the microSD card through the card reader.

**Warning:**

- Ensure that the SD card slot and the microSD card are clean and free of foreign objects during use.
- DO NOT remove the microSD card from the drone when taking photos or videos. Otherwise, the microSD card may be damaged.
- Check camera settings before use to ensure they are configured correctly.

Material Transfer

Follow the steps below to quickly download photos and videos from the drone to your mobile device.

1. Power on the drone and wait until the self-diagnostic tests of the drone are complete.
2. Turn on the Bluetooth and Wi-Fi on the mobile device, and make sure the positioning function is enabled as well.
3. Enter QuickTransfer mode using one of the methods below.
 - Launch the flight control app and tap the Material Transfer card on the home screen.
 - Launch the flight control app, go to Gallery, and tap  in the upper right corner.
4. Once successfully connected, the files on the drone can be accessed and downloaded at high speed. Note that when connecting the mobile device to the drone for the first time, press and hold the power button of the drone to confirm.



Warning:

- Use Material Transfer in an unobstructed environment with no interference and stay away from sources of interference such as wireless routers, Bluetooth speakers, or headphones.

Chapter 7. Remote Controller

Remote Controller Without a Screen

Powering On/Off

Press the power button once to check the current battery level.

Press, then press and hold to power the remote controller on or off.

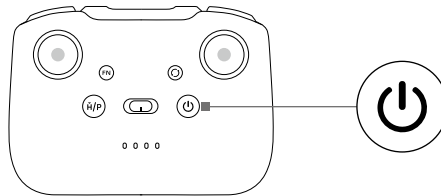

Charging the Remote Controller

Connect a charger to the USB-C port on the remote controller.

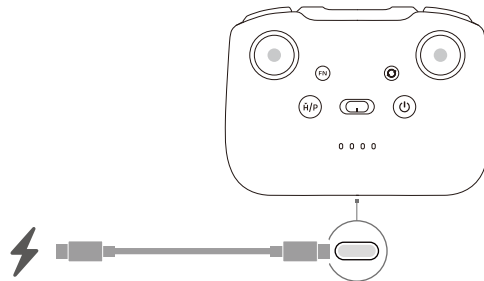

Warning:

- Charge the remote controller fully prior to each flight. An audible alert will sound when the battery level becomes low.
- Fully charge the battery at least once every three months to maintain battery health.

Controlling the Gimbal and Camera



1. **Customizable Button:** Press and hold the customizable button and then use the gimbal dial to zoom in or out.
2. **Photo/Video Button:** Press once to switch between photo and video mode.

- 3. **Gimbal Dial:** Control the tilt of the gimbal.
- 4. **Shutter/Record Button:** Press once to take a photo or to start or stop recording.

Flight Mode Switch

Toggle the switch to select the desired flight mode.

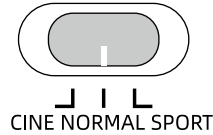

Flight Pause/RTH Button

Press once to make the drone brake and hover in place.

Press and hold the button until the remote controller beeps and starts RTH. The drone will return to the last recorded Home Point. Press the button again to cancel RTH and regain control of the drone.

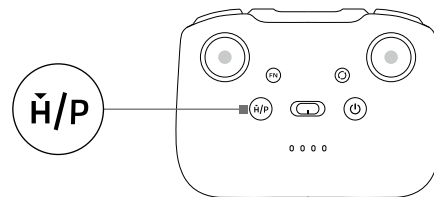



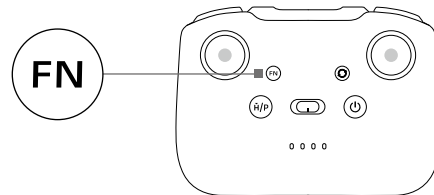

Customizable Button

To view and set the button function, go to camera view in the flight control app, and tap  > **Control** > **Button Customization**.



Battery Level LEDs

Blinking Pattern	Battery Level
	76-100%
	51-75%
	26-50%
	0-25%

Remote Controller Alert

The remote controller sounds an alert during RTH, which cannot be cancelled. The remote controller sounds an alert when the battery level of the remote controller is low. A low battery level alert can be cancelled by pressing the power button. When the battery level is critically low, the alert cannot be cancelled.

There will be an alert if the remote controller is not used for a period while it is powered on but is not connected to the drone or the flight control app on the smartphone. The remote controller will automatically power off after the alert stops. Move the control sticks or press any button to cancel the alert.

Optimal Transmission Zone

The signal between the drone and the remote controller works most reliably when the antennas are oriented relative to the drone as shown below. If the signal is weak, reposition the remote controller, or fly the drone closer to the remote controller.

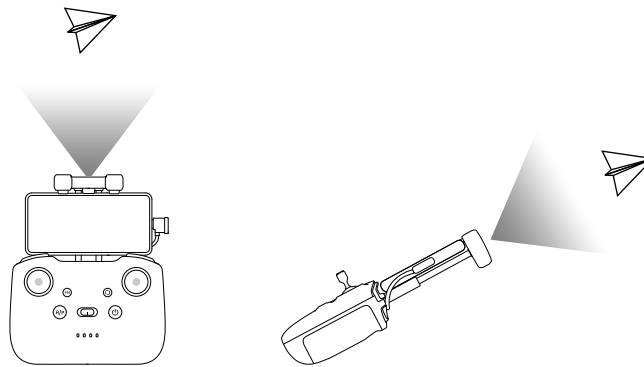

Warning:

- Do not use other wireless devices operating at the same frequency as the remote controller.
- An alert will appear in the app if the transmission signal becomes weak during flight. Reorient the remote controller according to the attitude indicator to ensure the drone remains within the optimal transmission zone.

Linking the Remote Controller

If purchased as a combo, the remote controller and drone are pre-linked. If purchased separately, follow the steps below to link them.

1. Power on the drone and the remote controller.
2. Launch the flight control app on your smartphone.
3. In camera view, tap  > **Control** > **Connect to Aircraft**. During linking, the remote controller beeps.
4. Press and hold the power button of the drone for more than four seconds. The drone beeps, and its battery level LEDs blink in sequence to indicate it is ready to link. The remote controller will beep twice to indicate linking is successful.



Tip:

- Make sure the remote controller is within 0.5 m of the drone during linking.
- The remote controller will automatically unlink from the drone if a new remote controller is linked to the same drone.

Remote Controller With a Screen

Powering On/Off

Press the power button once to check the current battery level.

Press, then press and hold to power the remote controller on or off.

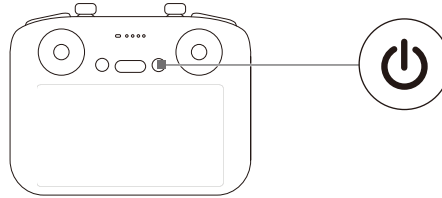

Charging the Remote Controller

Connect a charger to the USB-C port on the remote controller.

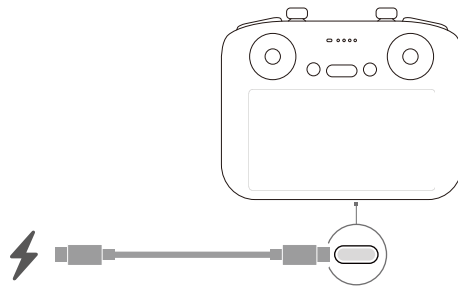

Warning:

- Charge the remote controller fully prior to each flight. An audible alert will sound when the battery level becomes low.
- Fully charge the battery at least once every three months to maintain battery health.

Controlling the Gimbal and Camera

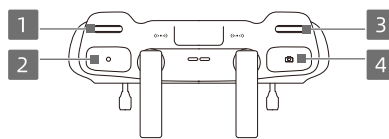

1. **Gimbal Dial:** Adjusts the gimbal's tilt angle.
2. **Record Button:** Press once to begin or end recording.
3. **Camera Control Dial:** By default, this dial adjusts the zoom setting. It can be configured to other functions in the flight control app.
4. **Focus/Shutter Button:** Press halfway to trigger auto-focus and press fully to capture a photo.

Flight Mode Switch

Toggle the switch to select the desired flight mode.

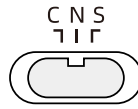

Flight Pause/RTH Button

Press once to make the drone brake and hover in place.

Press and hold the button until the remote controller beeps and starts RTH. The drone will return to the last recorded Home Point. Press the button again to cancel RTH and regain control of the drone.

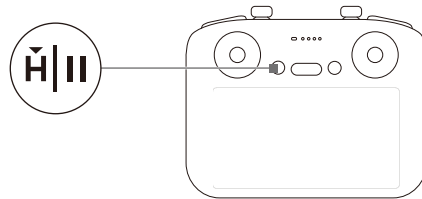

Customizable Buttons

To view and set the button function, go to camera view in the flight control app, and tap > **Control** > **Button Customization**.

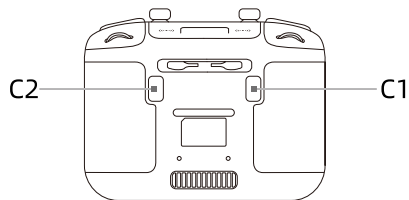



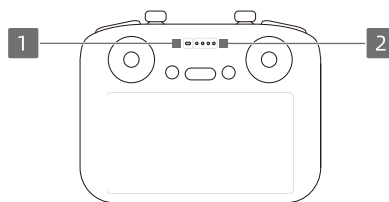



Remote Controller LEDs







1. Status LED
2. Battery Level LEDs

Status LED

Blinking Pattern		Descriptions
	Solid red	Not connected to the drone.

Blinking Pattern		Descriptions
	Blinking red	The drone's battery level is low.
	Solid green	Paired with the drone.
	Blinking blue	Pairing with a drone.
	Solid yellow	Firmware update unsuccessful.
	Solid blue	Firmware update successful.
	Blinking yellow	The remote controller's battery level is low.
	Blinking cyan	Control sticks not at center position.

Battery Level LEDs

Blinking Pattern	Battery Level
	76-100%
	51-75%
	26-50%
	0-25%

Remote Controller Alert

The remote controller emits beeps to signal an error or warning. Watch for alerts appearing on the touchscreen or in the app.

Swipe down from the top of the screen and tap Mute to turn off all alerts, or drag the volume slider to 0 to turn off some alerts.

The remote controller will beep during RTH, and this alert cannot be silenced. When the battery level is low, the remote controller will beep. A low battery alert can be dismissed by pressing the power button. When the battery reaches a critically low level, the alert cannot be dismissed.

If the remote controller remains powered on but not connected to the drone for an extended period, an alert will sound. It will shut down on its own after the alert ends. Press any button or move the control sticks to stop the alert.

Optimal Transmission Zone

The signal between the drone and the remote controller works most reliably when the antennas are oriented relative to the drone as shown below. If the signal is weak, reposition the remote controller, or fly the drone closer to the remote controller.

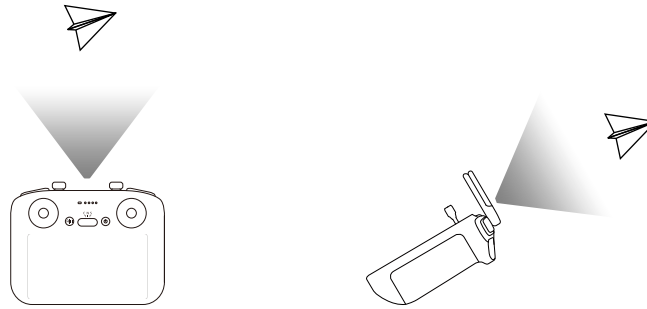

Warning:

- Do not use other wireless devices operating at the same frequency as the remote controller.
- An alert will appear in the app if the transmission signal becomes weak during flight. Reorient the remote controller according to the attitude indicator to ensure the drone remains within the optimal transmission zone.

Linking the Remote Controller

If purchased as a combo, the remote controller and drone are pre-linked. If purchased separately, follow the steps below to link them.

1. Power on the drone and the remote controller.
2. Launch the flight control app.
3. In camera view, tap *** > **Control** > **Connect to Aircraft**. During linking, the remote controller's status LED will flash blue and the remote controller will beep.
4. Press and hold the power button of the drone for more than four seconds. The drone beeps, and its battery level LEDs blink in sequence to indicate it is ready to link. The remote controller will beep twice, and its status LED will display solid green to indicate linking is successful.

Tip:

- Make sure the remote controller is within 0.5 m of the drone during linking.
- The remote controller will automatically unlink from the drone if a new remote controller is linked to the same drone.

Operating the Touchscreen

Warning:

- Be aware that the touchscreen lacks waterproof protection. Handle with care.

Screen Gestures

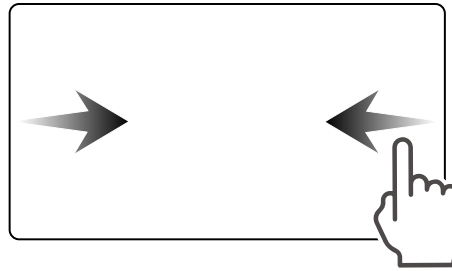

Back: Swipe from the left or right edge toward the center to go back to the previous screen.

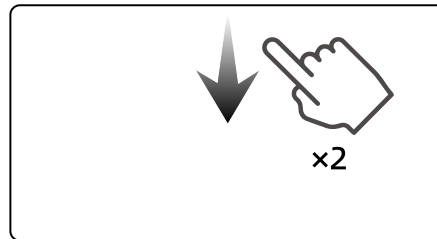

Open Quick Settings: Swipe down two times from the top edge to access Quick Settings when in the flight control app.

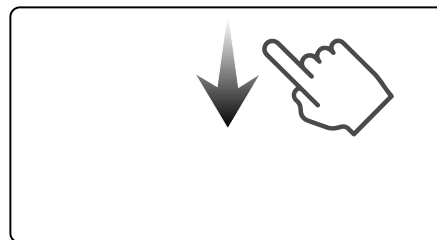

Open the status bar: Swipe downward from the top edge to display the status bar when in the flight control app.

The status bar shows the time, Wi-Fi signal, battery level of the remote controller, and more.